

**NASA TECHNICAL
MEMORANDUM**

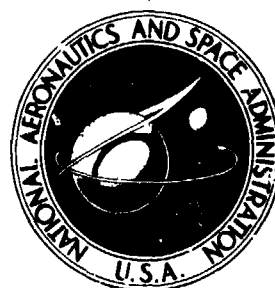

NASA TM X-3126

NASA TM X-3126

**MEASUREMENTS OF SONIC BOOMS
GENERATED BY AN AIRPLANE
FLYING AT MACH 3.5 AND 4.8**

by Karen S. Green and Terrill W. Putnam

*Flight Research Center
Edwards, Calif. 93523*



NATIONAL AERONAUTICS AND SPACE ADMINISTRATION • WASHINGTON, D. C. • OCTOBER 1974

**MEASUREMENTS OF SONIC BOOMS GENERATED BY AN
AIRPLANE FLYING AT MACH 3.5 AND 4.8**

**Karen S. Green and Terrill W. Putnam
Flight Research Center**

INTRODUCTION

Since the advent of supersonic flight, sonic booms have become an increasingly serious problem. Studies of a community's tolerance to frequent sonic booms (refs. 1 and 2) revealed that lower overpressures than expected elicited strong objections from the populace.

The proposed space shuttle will reenter the earth's atmosphere at high supersonic speeds and will generate a sonic boom while passing over populated areas. Sonic booms generated by aircraft flying at speeds up to Mach 3 have been measured and evaluated (ref. 3), but no sonic boom data are available for airplanes flying at higher speeds. Although measurements were made of sonic booms generated at Mach numbers up to 16 during lift-off and reentry of the Apollo spacecraft (ref. 4), the vehicle had a blunt-shaped body quite unlike that of the proposed space shuttle. Consequently, sonic boom data are needed for a slender-body vehicle that operates at Mach numbers greater than 3 to increase confidence in the predicted sonic boom characteristics of the space shuttle for altitudes below 30,000 meters.

This report examines sonic boom overpressure signatures generated by the X-15 rocket-powered airplane during one flight at high altitudes and Mach numbers of 3.5 and 4.8. The measured sonic boom overpressures and the results obtained from theoretical methods of estimating overpressure are compared.

SYMBOLS

Physical quantities in this report are given in the International System of Units (SI). Measurements were taken in U.S. Customary Units. Factors relating the two systems are given in reference 5.

d diameter, meters

K_1	ground reflection factor
K_2	airplane volume-shape factor
K_3	airplane lift-shape factor
l	airplane length, meters
l_w	airplane wing root-chord length, meters
M	Mach number
p_a	ambient pressure at altitude, pascals*
p_o	ambient pressure at ground level, pascals
Δp_L	calculated pressure rise across shock wave at ground level based on airplane lift, pascals
Δp_{L+V}	calculated pressure rise across shock wave at ground level based on airplane lift and volume, pascals
Δp_m	measured pressure rise, pascals
Δp_s	measured pressure rise scaled to SR-71 airplane, pascals
Δp_V	calculated pressure rise across shock wave at ground level based on airplane volume, pascals
y	distance from measuring station perpendicular to flightpath, meters
W	airplane lift force, newtons

TEST AIRPLANE

The X-15 airplane was a rocket-powered research vehicle designed to attain hypersonic speed and altitudes in excess of 76,200 meters. Figure 1 is a three-view drawing of the X-15-3 airplane, which was used in this study. The overall length of the airplane was 15.1 meters, and the wingspan was 6.8 meters. The total cross-sectional area distribution is shown in figure 2. The empty gross weight was 6666 kilograms, and the launch weight was 14,965 kilograms. The airplane is described in detail in reference 6.

*Unit of pressure equivalent to newton per meter² (ref. 5).

TEST CONDITIONS

Test Area

The test flight was made over the Edwards Air Force Base test range. The ground track is shown in figure 3. The terrain in which measurements were taken was generally flat with no vegetation, as shown in figure 4. Goldstone Dry Lake, elevation 934.5 meters, and Cuddeback Dry Lake, elevation 792.5 meters, were chosen as measuring sites because of their large, flat, reflecting surfaces of hard-packed, sandy clay and their accessibility from the NASA Flight Research Center. Goldstone Dry Lake is 100.9 kilometers and Cuddeback Dry Lake is 54.7 kilometers northeast of Edwards Air Force Base.

Environmental Conditions

Meteorological facilities were not available at the measuring sites, so data on the environmental conditions for the test area were obtained from the Edwards Air Force Base weather facility. Atmospheric pressure, temperature, wind speed, and wind direction are plotted as functions of geopotential altitude in figures 5(a) to 5(c). These soundings were taken near the time of the flight.

Flight Conditions

The X-15 airplane was launched from a B-52 airplane at an altitude of approximately 13,700 meters and a Mach number of 0.8. The engine burned for about 97 seconds and was shut down at a Mach number of 4.8 and an altitude of 21,671 meters. Partial time histories for selected airplane parameters are shown in figure 6. The times the sonic booms were generated over the Goldstone and Cuddeback measuring sites are indicated. The times were computed from the airplane Mach number, the geometric relationship between the airplane and the measurement locations, and the temperature profile between the ground and the flight altitude. The sharp decrease in longitudinal acceleration 97 seconds after launch indicates engine shutdown and corresponds to the maximum Mach number and altitude. Angle of attack was maintained at less than 3° .

The primary flight objective required that a low level of longitudinal acceleration be maintained; thus the speed brakes were extended (fig. 7) and the engine was throttled to 50 percent of maximum thrust. The boom received at Goldstone Dry Lake was generated while the airplane was in this configuration. The boom received at Cuddeback Dry Lake was generated while the engine was not operating and the speed brakes were retracted.

Pertinent flight conditions at the times the booms were generated are summarized in the following table:

Condition	Measuring site	
	Goldstone Dry Lake	Cuddeback Dry Lake
Time after launch, sec	95	129
Mach number	4.8	3.5
Altitude, m	21,450	20,350
Longitudinal acceleration, g	0.1	-1.2
Normal acceleration, g	1.1	1.0
Speed brakes	Extended 40°	Retracted
Rocket engine	50-percent thrust	Shut down

The X-15 ground tracks relative to the microphone arrays at Goldstone Dry Lake and Cuddeback Dry Lake are shown in figures 8(a) and 8(b), respectively. Although the flight plan called for the airplane to fly directly over the microphone arrays, it can be seen that it actually passed 2740 meters south of Goldstone Dry Lake and 12,649 meters south of Cuddeback Dry Lake.

INSTRUMENTATION

The main elements of the ground systems used for these sonic boom measurements are described in detail in reference 2. The basic equipment included a 2.54-centimeter-diameter condenser microphone modified by partially plugging the vent hole to extend the low frequency response; an oscillograph recorder; a direct current amplifier; a tuning circuit; and a magnetic tape recorder. Frequency response was calibrated in the laboratory from 0.02 hertz to 10,000 hertz ± 2 decibels (ref. 0.00002 Pa), and the microphones had a dynamic range from approximately 70 decibels to 150 decibels. Sound pressure level calibrations were made in the field with a discrete frequency calibrator.

The microphone arrays were positioned on the lakebeds as shown in figures 9(a) and 9(b). At each site one microphone was mounted on a 6.1-meter high pole at the head of the T-shaped array with the diaphragm parallel to the ground. The remaining seven microphones were ground plane instruments mounted as shown in the figure insets. The microphones at Goldstone Dry Lake were shock-mounted (fig. 4) 0.15 meter above the ground with the microphone diaphragm parallel to the lakebed surface. The microphones at Cuddeback Dry Lake were mounted with the diaphragm at ground level. The two types of mounting arrangements resulted in only very small differences in waveform (ref. 1).

At Cuddeback Dry Lake the data were recorded directly on the recording oscillograph. The Goldstone Dry Lake data were recorded first on magnetic tape at 0.762 meter per second. Then, after the flight, the data were played back from the tape and recorded on an oscillograph recorder to obtain a graphic copy of the sonic boom signatures.

The instrumentation system used in this study was identical to that used in the investigation of reference 7, which established the overall accuracy for this type of

instrumentation, considering instrument calibration and measuring and reading procedures, as ± 15 percent.

RESULTS AND DISCUSSION

The sonic boom overpressure signatures from Goldstone Dry Lake and Cuddeback Dry Lake are shown in figures 10 and 11, respectively, in time sequential order. The waveforms are of the N-wave type. The pressure signatures are not directly comparable because of differences in the sensitivity of various channels of the recording equipment. The signatures from Cuddeback Dry Lake are more rounded than those from Goldstone Dry Lake. This is consistent with other sonic boom data (ref. 3) which show that sonic boom signatures become rounder with increasing lateral distance from the ground track. The sonic boom signatures measured by the pole microphones at both measuring sites show a step in the initial overpressure rise. The first rise in pressure is caused by the pressure from the incident shock wave, and the second pressure rise results from the addition of the reflected shock wave to the incident shock wave. The overpressures range from 27.8 pascals to 42.1 pascals at Goldstone Dry Lake and from 20.1 pascals to 27.3 pascals at Cuddeback Dry Lake.

Theoretical analysis of sonic boom phenomena has indicated that the signature overpressures can be attributed to airplane volume and lift (ref. 8). Volume has been shown to be dominant at low altitudes, and lift, which is dependent on the type of aircraft, becomes dominant at altitudes of 14,900 meters and above for vehicles similar to the X-15 airplane (ref. 9). The effects of lift and volume on the overpressures were calculated for the present investigation by using equations (1) and (2) in the appendix.

The average overpressure measured by the seven ground plane microphones at Goldstone Dry Lake was 34.4 pascals; the theoretical overpressure was 31.4 pascals. The average overpressure measured at Cuddeback Dry Lake by the ground plane microphones was 25.0 pascals; the theoretical overpressure was 28.5 pascals. Thus the theoretical and measured overpressures agreed within 12 percent.

The Mach 4.8 sonic boom data from the ground plane microphones at Goldstone Dry Lake are compared in figure 12 with sonic boom data for an SR-71 airplane (ref. 3). The X-15 and SR-71 peak overpressures were not directly comparable because of differences in the sizes and weights of the airplanes; therefore, the X-15 data were scaled to the weight and wing root-chord length of the SR-71 by using equation (1). The X-15 data are in good agreement with the SR-71 data when only the lift equation was used to scale the data. As noted previously, at altitudes of 14,900 meters and above, overpressures due to lift dominate in the total overpressures for vehicles with slender bodies, such as the X-15 and the SR-71 airplanes. The Mach 3.5 sonic boom data from Cuddeback Dry Lake were not plotted because they were obtained at a greater lateral distance from the ground track than the SR-71 data.

CONCLUDING REMARKS

Sonic boom measurements were made for the X-15 airplane flying at Mach numbers of 3.5 and 4.8. The experimental results agreed within 12 percent with results obtained by using theoretical methods. No unusual phenomena related to overpressure were encountered. Scaled data from the X-15 airplane flying at Mach 4.8 agreed with sonic boom data generated by an SR-71 airplane at lower Mach numbers and similar altitudes. The simple technique used to scale the data on the basis of airplane lift was satisfactory for comparing X-15 and SR-71 sonic boom signatures.

*Flight Research Center
National Aeronautics and Space Administration
Edwards, Calif., September 5, 1974*

APPENDIX

THEORETICAL CALCULATION OF OVERPRESSURES

The equation used to calculate the effect of airplane lift on overpressure was as follows:

$$\Delta p_L = \frac{K_1 \sqrt{p_a p_o} (M^2 - 1)^{3/8} K_3 W^{1/2} \ell_w^{3/4}}{y^{3/4} p_a^{1/2} M \ell_w} \quad (1)$$

The ground reflection factor, K_1 , chosen was 1.8, which is the reflection factor for a sandy, flat surface (ref. 10). The airplane lift-shape factor, K_3 , varied for different lift distributions; however, an average value of 0.55 (ref. 9) was used. An airplane wing root-chord length, ℓ_w , of 3.35 meters was used. The rocket engine fuel was nearly exhausted at the time the sonic booms were generated; therefore, the empty aircraft weight was used in conjunction with the normal acceleration to arrive at lift forces of 71,925 newtons and 65,386 newtons, which were used in the computations of overpressure for the Goldstone and Cuddeback measuring sites, respectively.

The equation used to calculate the effect of airplane volume on overpressure was as follows:

$$\Delta p_V = \frac{K_1 \sqrt{p_a p_o} (M^2 - 1)^{3/8} K_2 d \ell^{3/4}}{y^{3/4} \ell} \quad (2)$$

The airplane volume-shape factor, K_2 , for an airplane similar to the X-15 airplane is given as 0.645 in reference 10, so that value was used. The overall length of the airplane, ℓ , was 15.1 meters. The diameter, d , used in the calculation was the diameter of a circle having an area equal to the maximum cross-sectional area of the airplane (ref. 6). The maximum cross-sectional area of the X-15 airplane was dependent on the speed brake position. Thus the diameters used in the calculations for the Goldstone and Cuddeback sonic booms were 2.38 meters and 2.01 meters, respectively.

The combined effects of lift and volume on the overpressures were determined by the procedure presented in reference 11. The equation used was as follows:

$$\Delta p_{L+V} = \sqrt{(\Delta p_L)^2 + (\Delta p_V)^2} \quad (3)$$

REFERENCES

1. Hilton, David A.; Huckel, Vera; Steiner, Roy; and Maglieri, Domenic J.: **Sonic-Boom Exposures During FAA Community-Response Studies Over a 6-Month Period in the Oklahoma City Area.** NASA TN D-2539, 1964.
2. Stanford Research Institute: **Sonic Boom Experiments at Edwards Air Force Base.** NSBEO-1-67, NTIS, U.S. Dep. Com., July 28, 1967. (Available from DDC as AD 655 310.)
3. Maglieri, Domenic J.; Huckle, Vera; and Henderson, Herbert R.: **Sonic-Boom Measurements for SR-7 Aircraft Operating at Mach Numbers to 3.0 and Altitudes to 24 384 Meters.** NASA TN D-6823, 1972.
4. Henderson, Herbert R.; and Hilton, David A.: **Sonic-Boom Ground Pressure Measurements From the Launch and Reentry of Apollo 16.** NASA TN D-7606, 1974.
5. Mechtly, E. A.: **The International System of Units - Physical Constants and Conversion Factors. Second Revision.** NASA SP-7012, 1973.
6. Saltzman, Edwin J.; and Garringer, Darwin J.: **Summary of Full-Scale Lift and Drag Characteristics of the X-15 Airplane.** NASA TN D-3343, 1966.
7. Hubbard, Harvey H.; Maglieri, Domenic J.; Huckel, Vera; and Hilton, David A. (with appendix by Harry W. Carlson): **Ground Measurements of Sonic-Boom Pressures for the Altitude Range of 10,000 to 75,000 Feet.** NASA TR R-198, 1964. (Supersedes NASA TM X-633.)
8. Morris, John: **An Investigation of Lifting Effects on the Intensity of Sonic Booms.** J. Roy. Aeron. Soc., vol. 64, no. 598, Oct. 1960, pp. 610-616.
9. Maglieri, Domenic J.; and Hubbard, Harvey H.: **Ground Measurements of the Shock-Wave Noise From Supersonic Bomber Airplanes in the Altitude Range From 30,000 to 50,000 Feet.** NASA TN D-880, 1961.
10. Maglieri, Domenic J.; Hubbard, Harvey H.; and Lansing, Donald L.: **Ground Measurements of the Shock-Wave Noise From Airplanes in Level Flight at Mach Numbers to 1.4 and at Altitudes to 45,000 Feet.** NASA TN D-48, 1959.
11. Carlson, Harry W.: **An Investigation of the Influence of Lift on Sonic-Boom Intensity by Means of Wind-Tunnel Measurements of the Pressure Fields of Several Wing-Body Combinations at a Mach Number of 2.01.** NASA TN D-881, 1961.

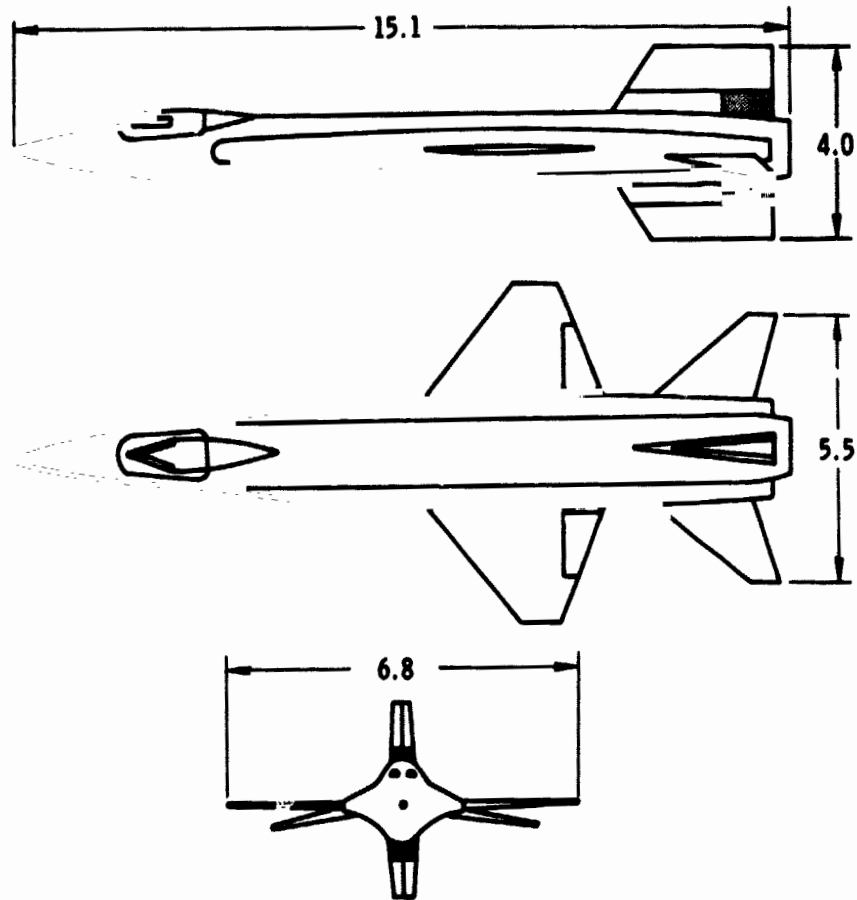

Figure 1. Three-view drawing of the X-15-3 airplane. Shaded areas denote speed brakes. Dimensions in meters.

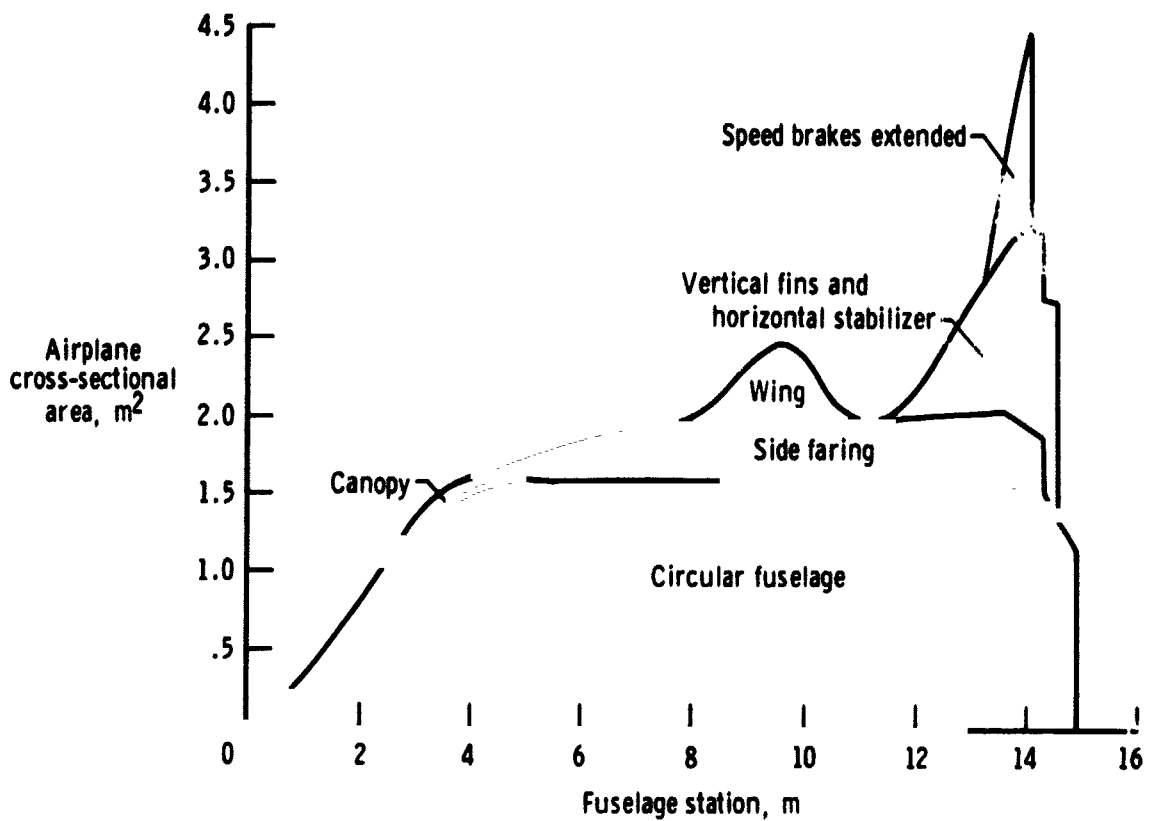

Figure 2. X-15-3 cross-sectional area distribution.

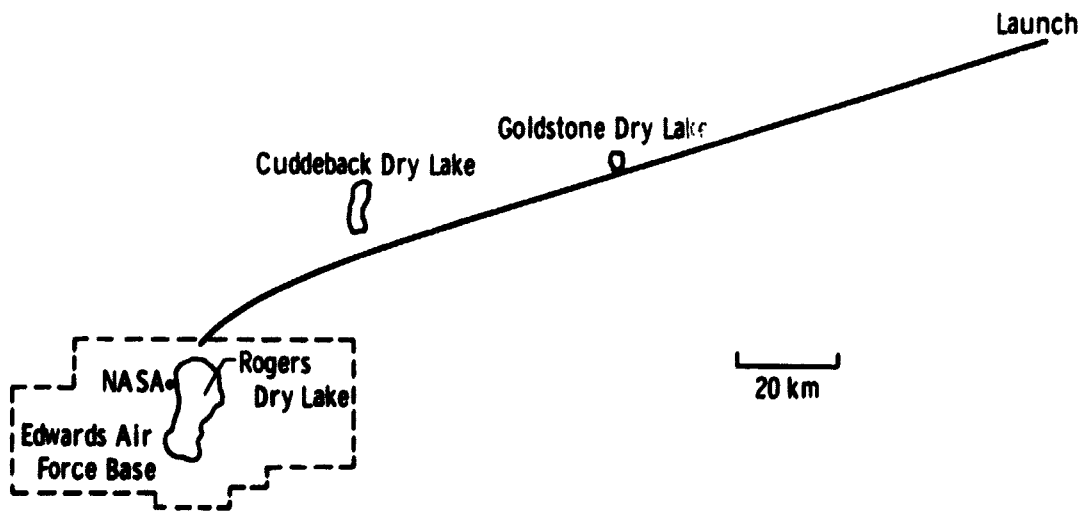

Figure 3. X-15 ground track.

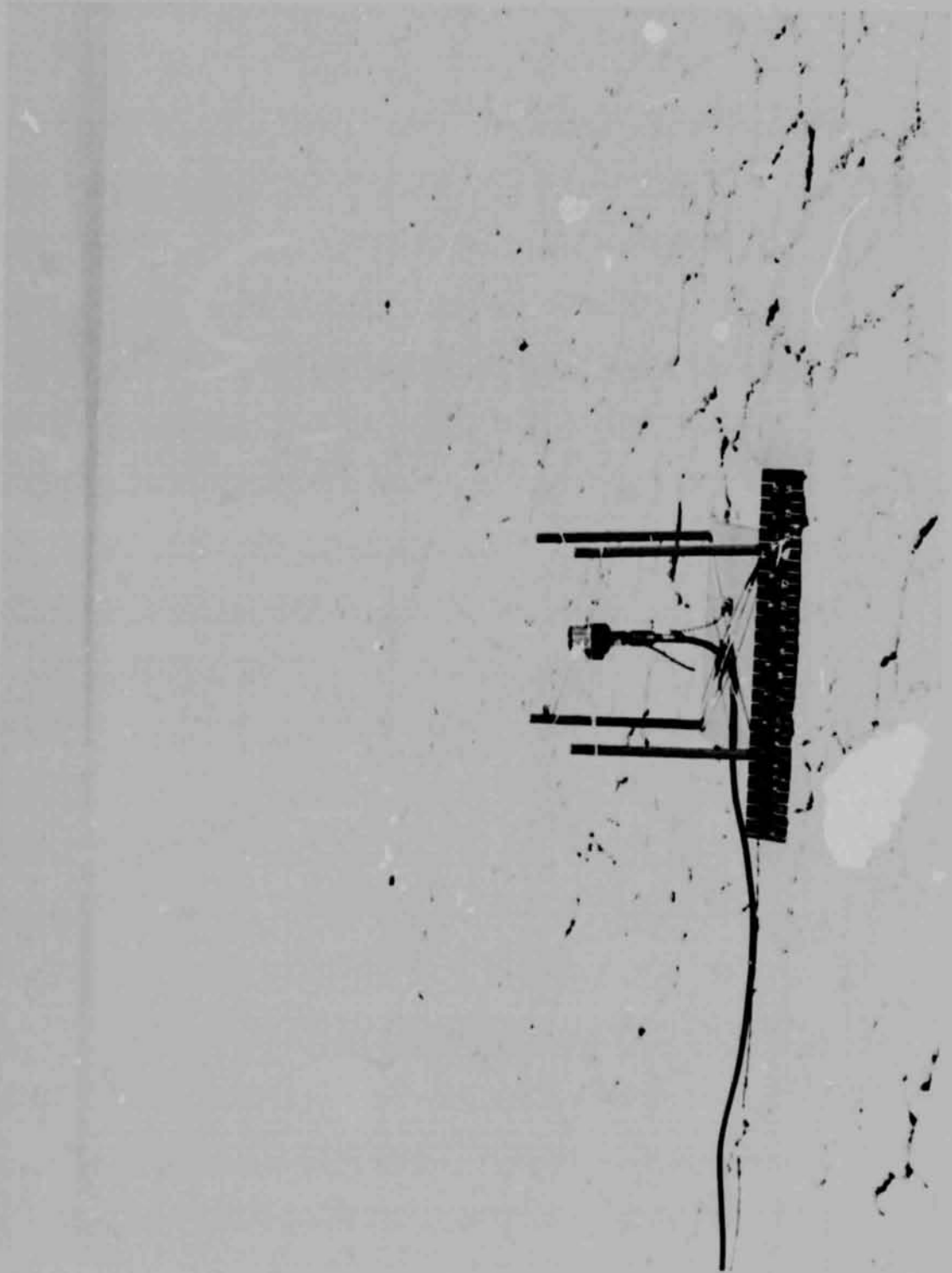
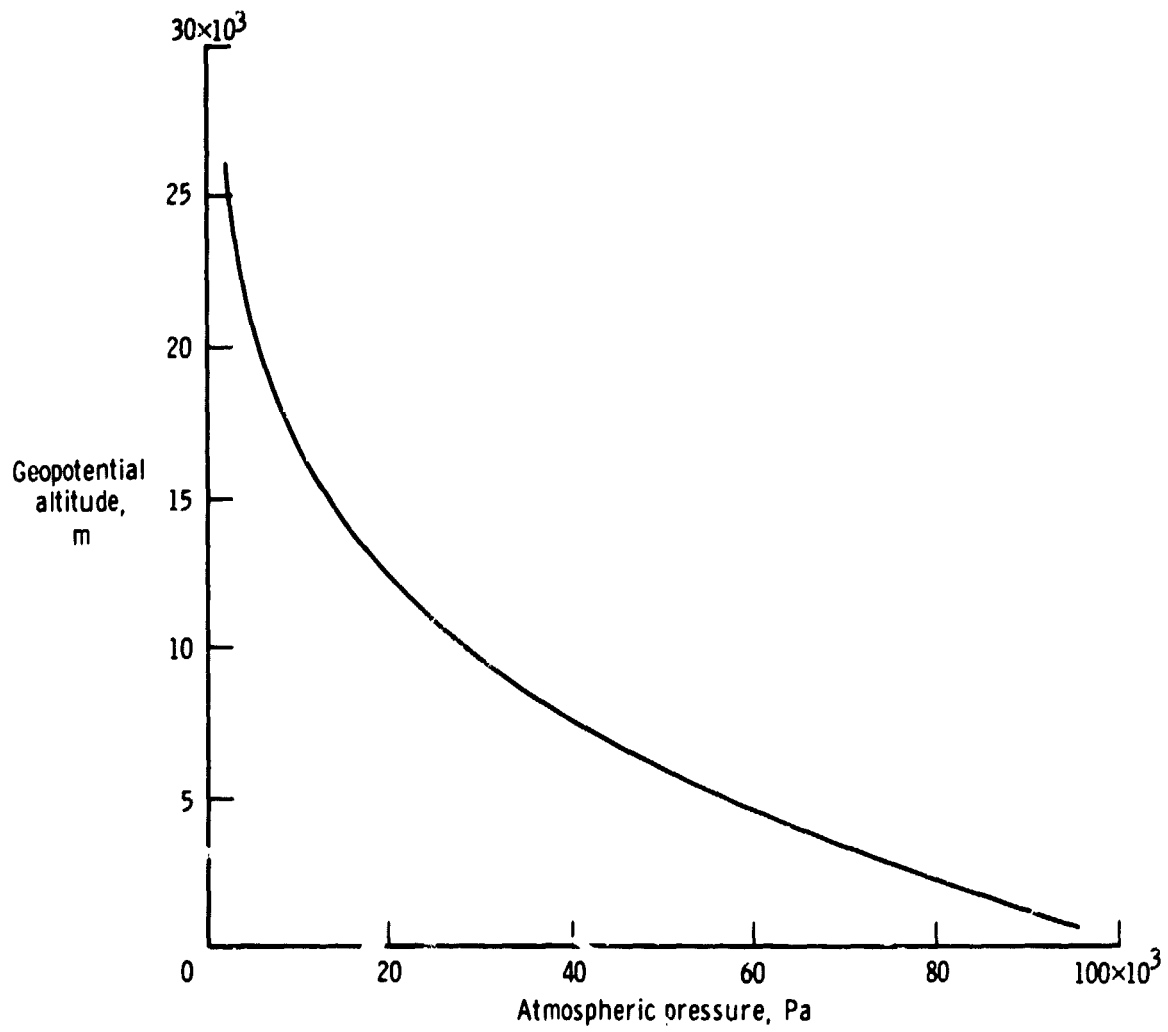
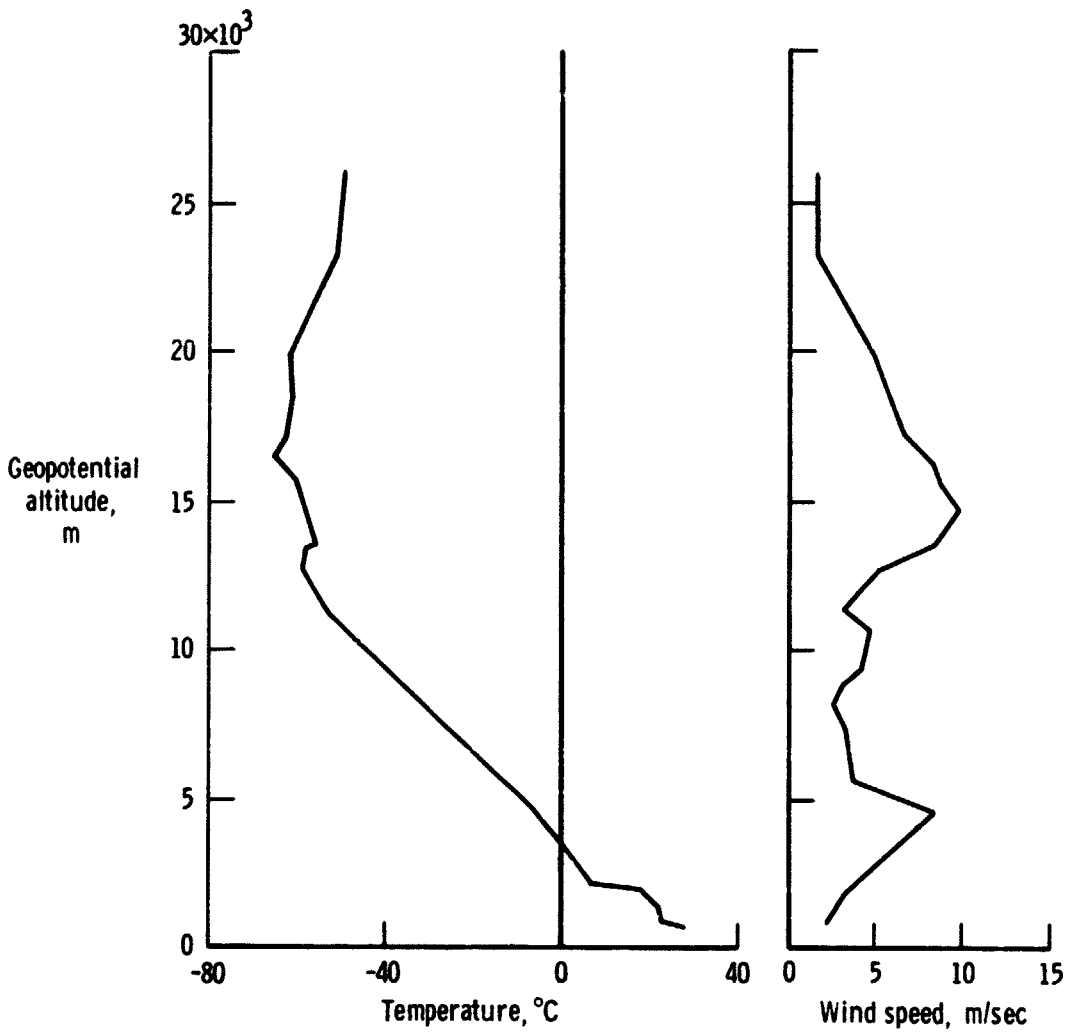

Figure 4. Photograph of test area showing shock-mounted microphone.



(a) Atmospheric pressure.

Figure 5. Meteorological conditions for the flight. (Data obtained from Edwards Air Force Base weather facility.)



(b) Temperature and wind speed.

Figure 5. Continued.

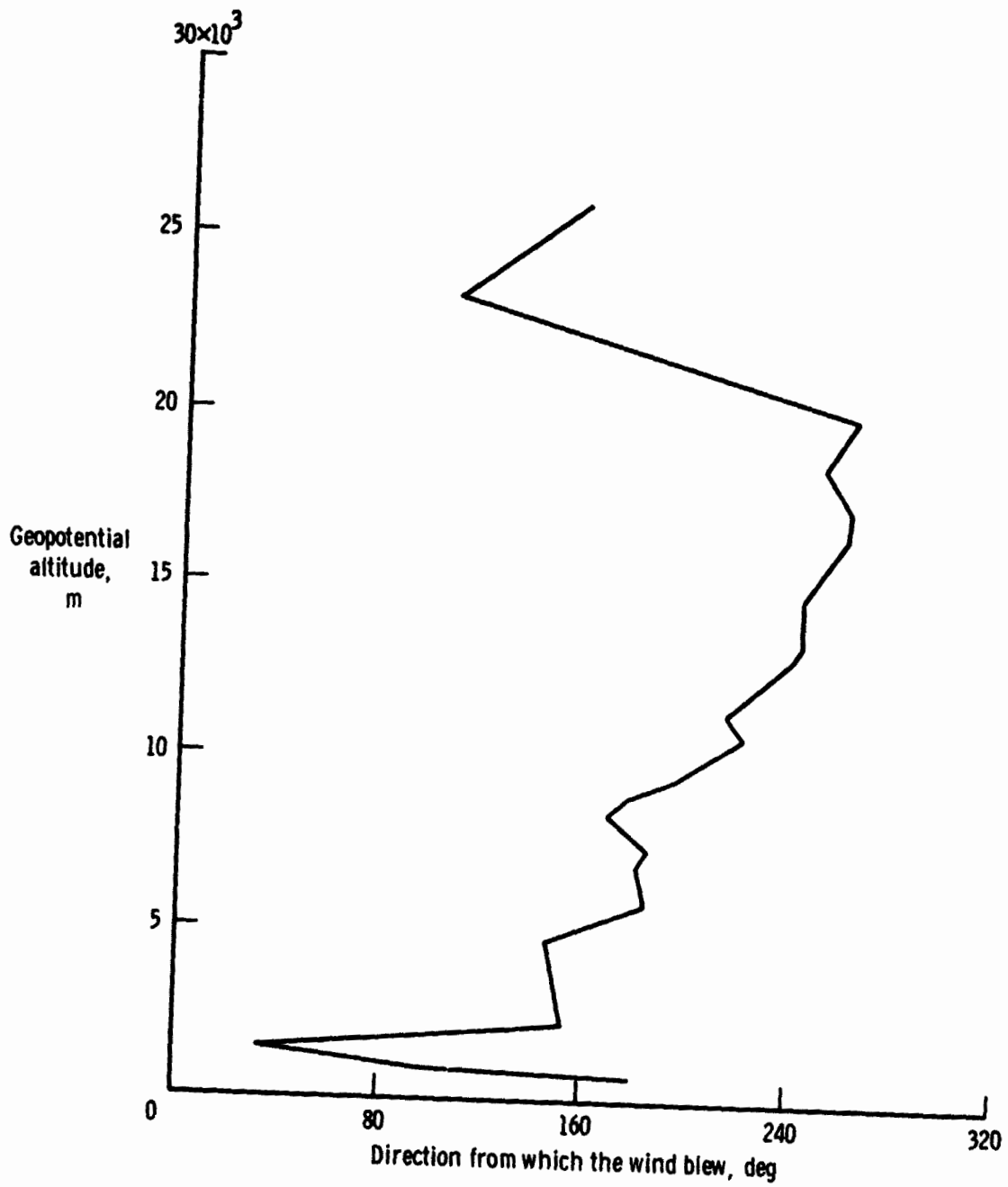

(c) Wind direction.

Figure 5. Concluded.

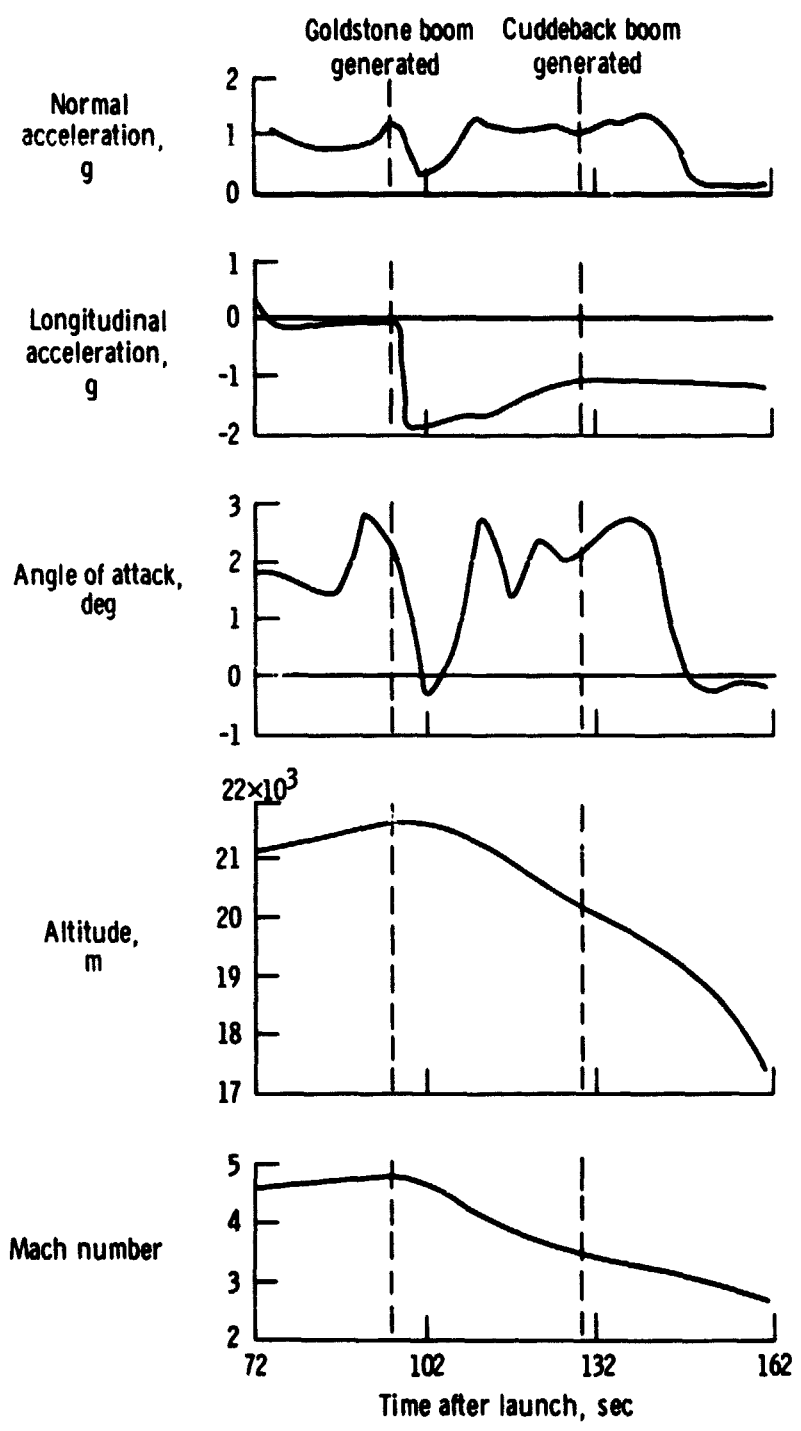

Figure 6. Time histories of selected airplane parameters.

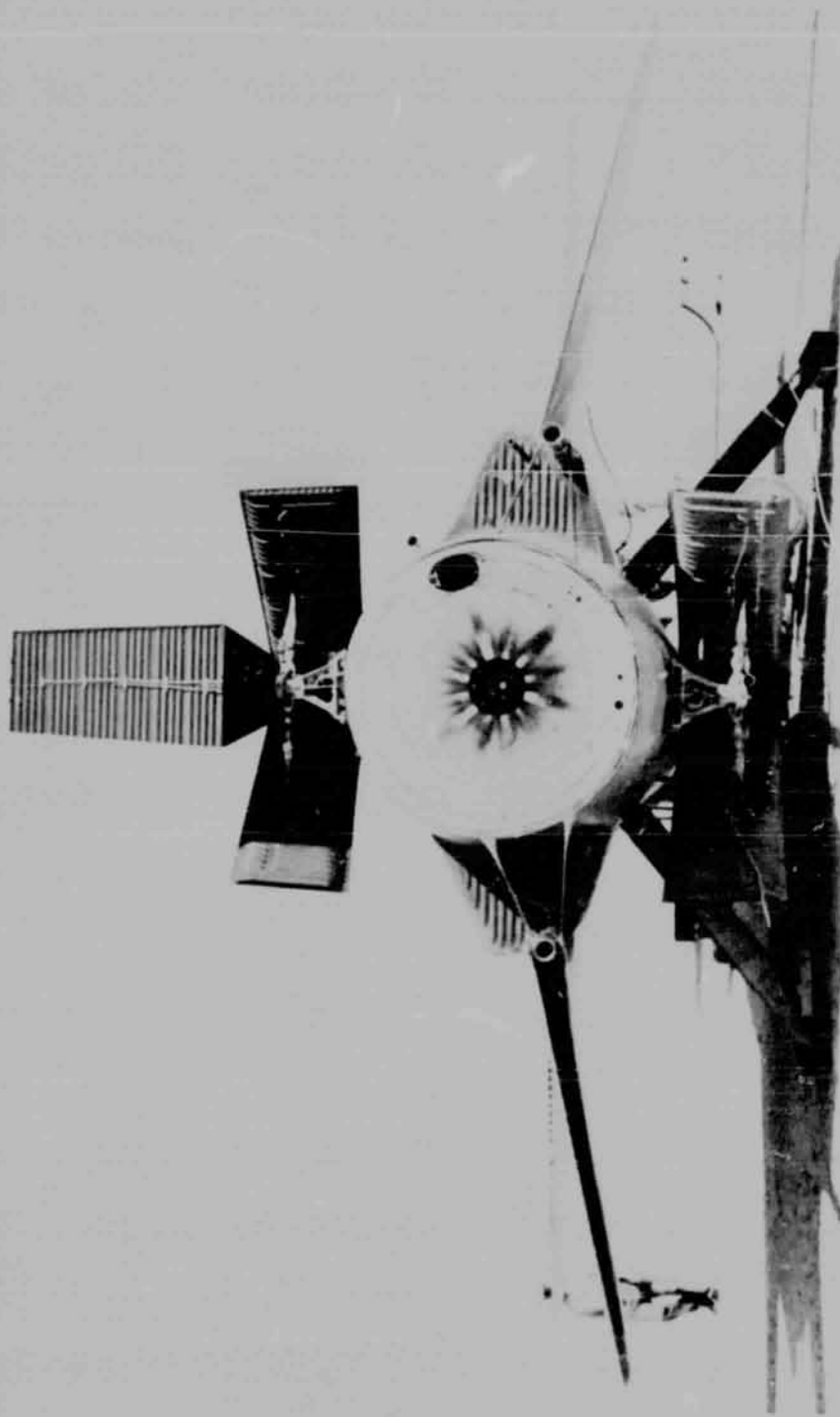
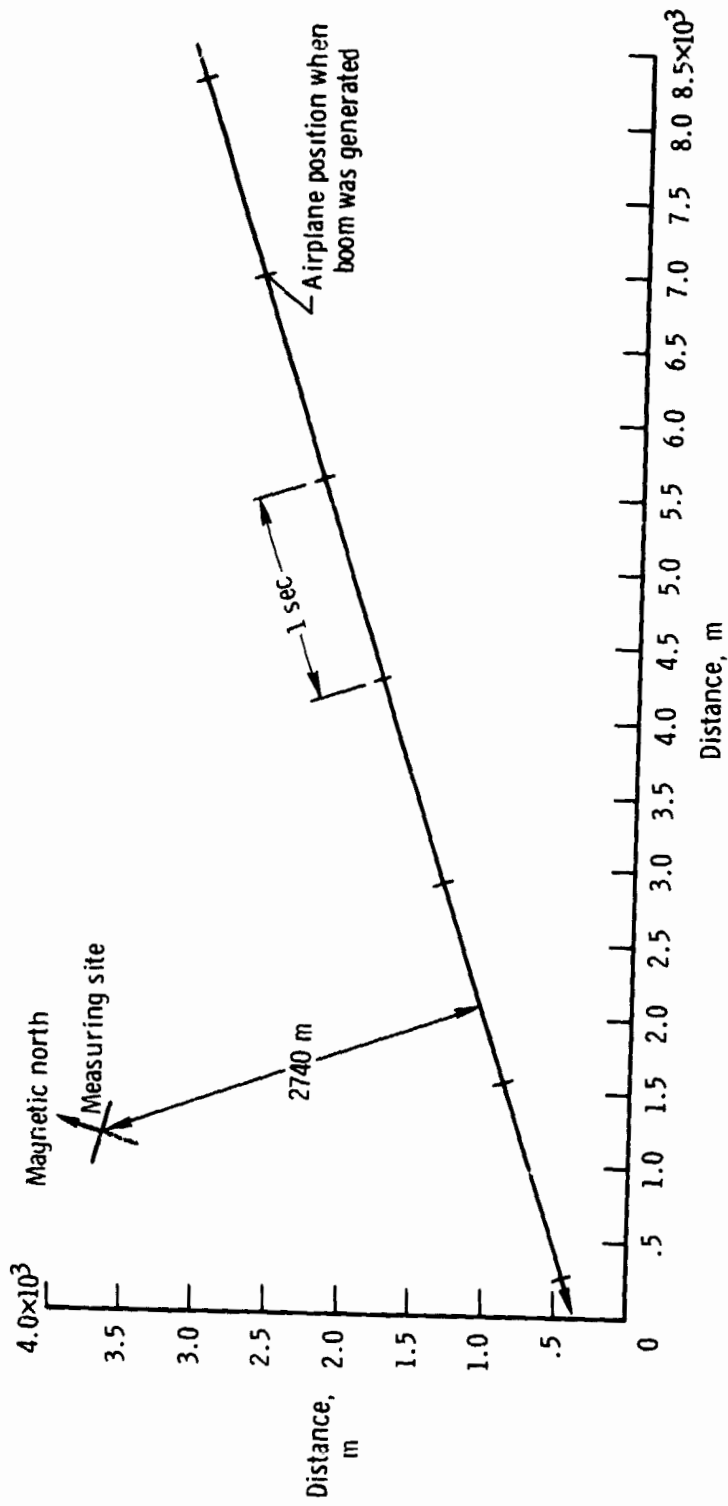
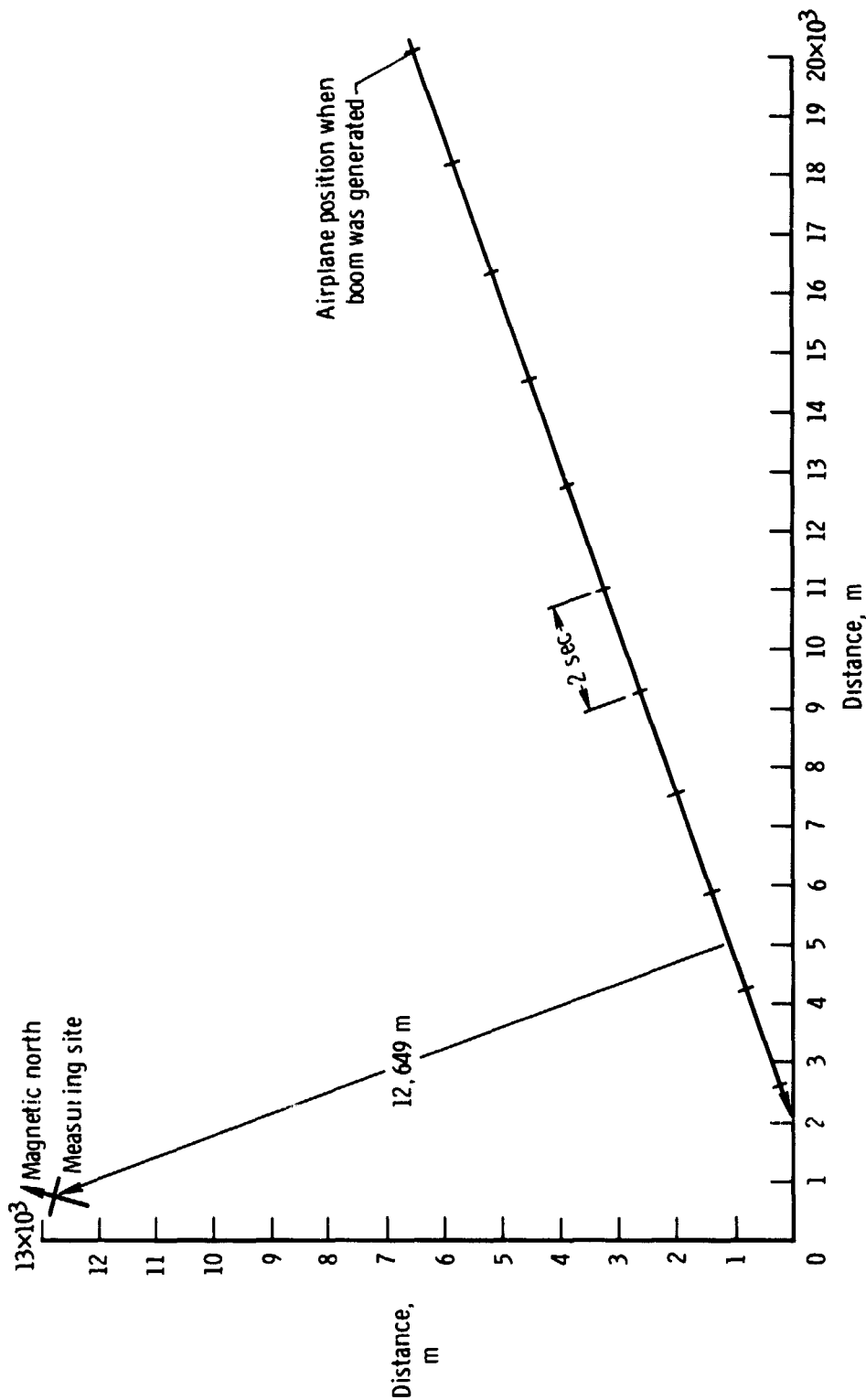

Figure 7. X-15-3 airplane with speed brakes extended.



(a) Goldstone Dry Lake.

Figure 8. X-15 ground tracks relative to measuring sites.



(b) Cuddeback Dry Lake.

Figure 8. Concluded.

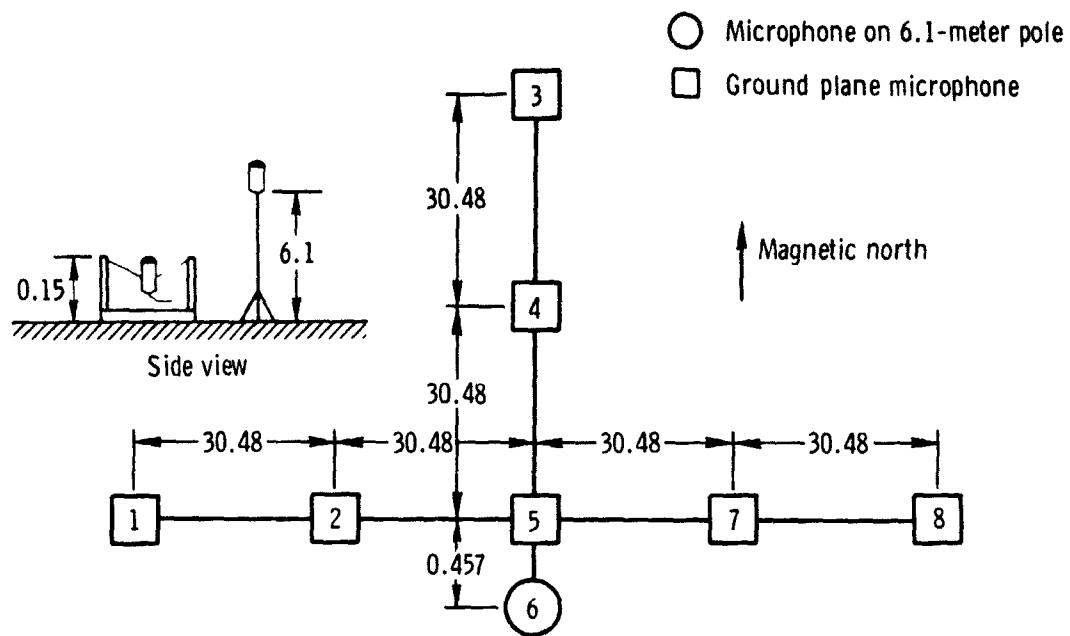

(a) Goldstone Dry Lake.

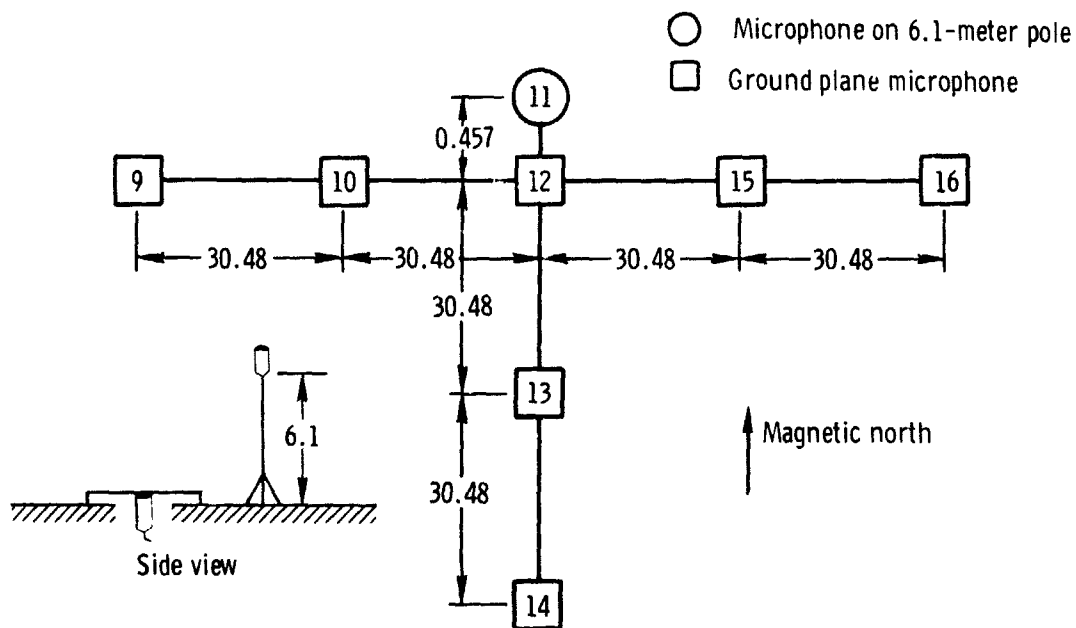

(b) Cuddeback Dry Lake.

Figure 9. Microphone arrays (not drawn to scale). Dimensions in meters.

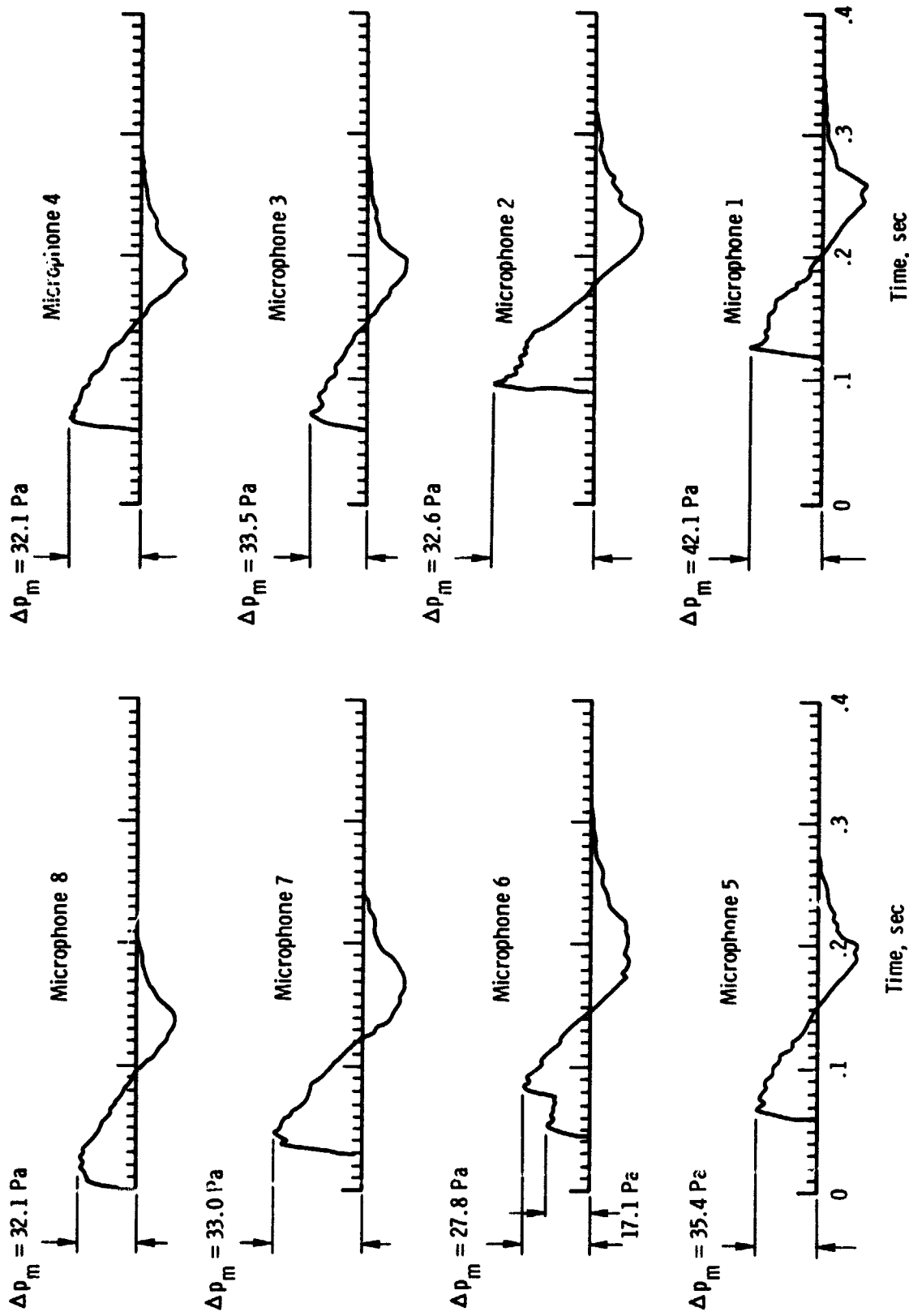

Figure 10. X-15 sonic boom signatures recorded at Goldstone Dry Lake. $M = 4.8$.

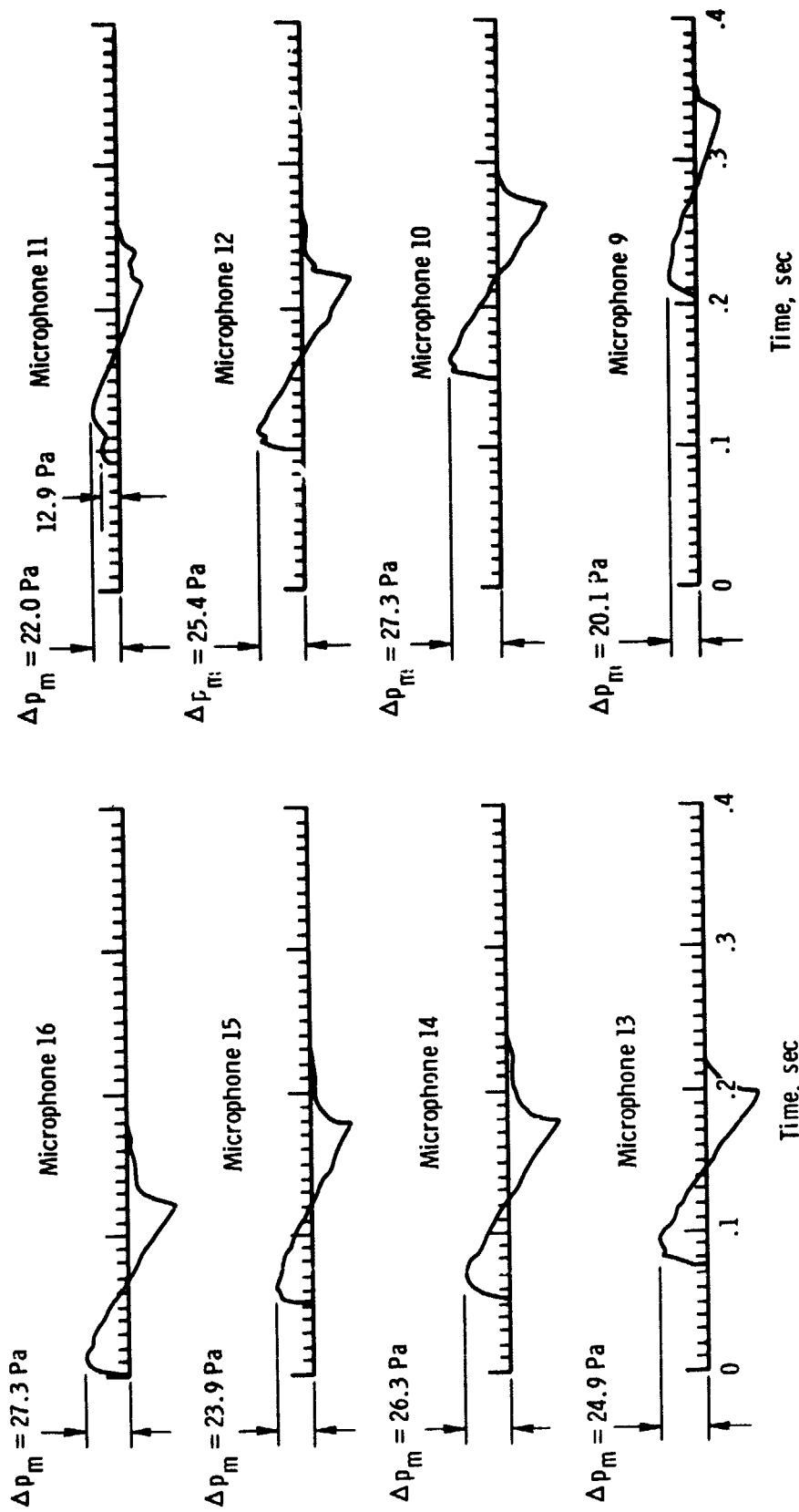

Figure 11. X-15 sonic boom signatures recorded at Cuddeback Dry Lake. $M = 3.5$.

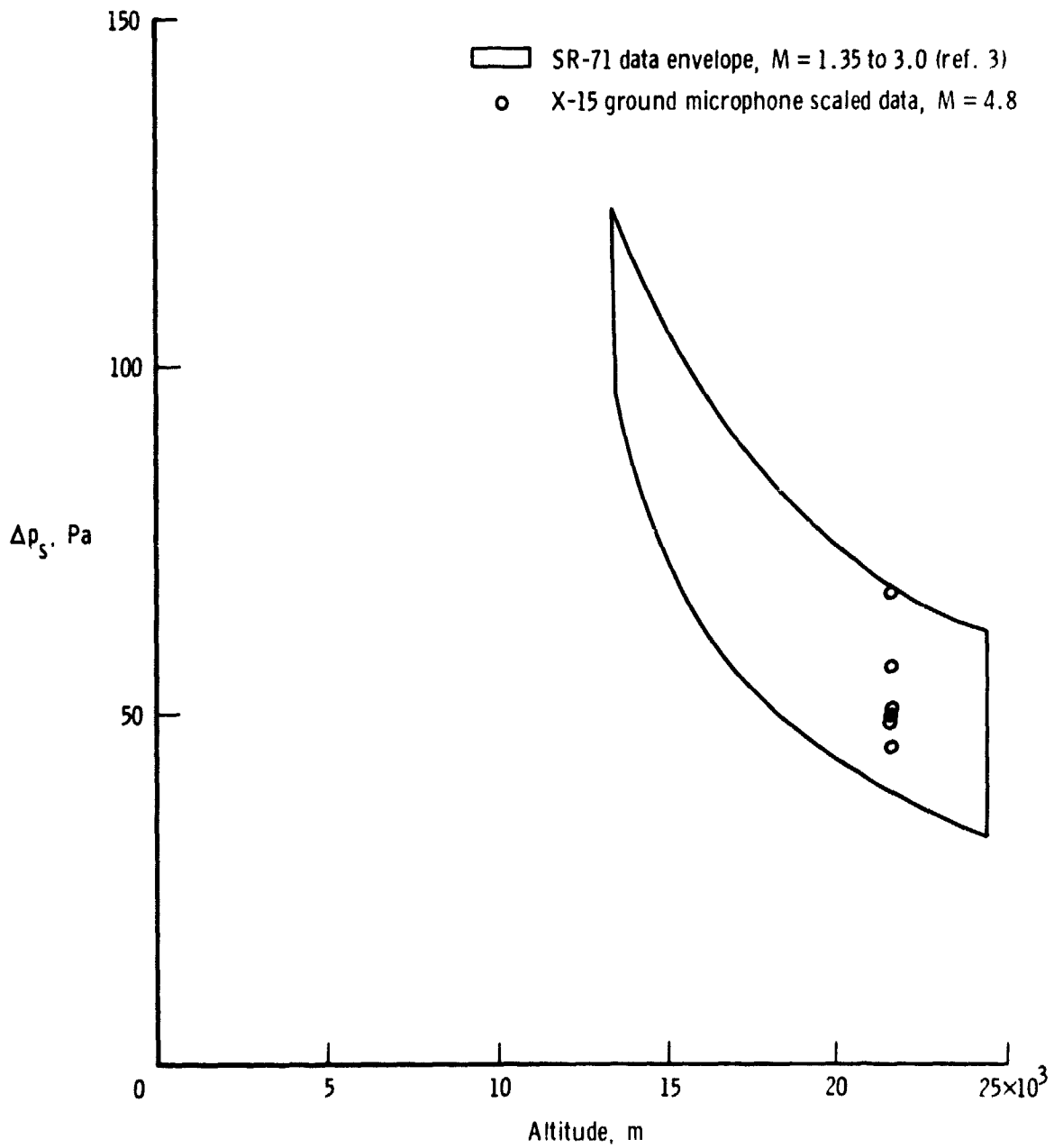

Figure 12. Comparison of scaled X-15 and SR-71 overpressure data measured within 5.5 kilometers of the ground track.